

Robex

80CR-9A

With Tier 4 Final Engine installed

MOVING YOU FURTHER

HYUNDAI HEAVY INDUSTRIES



*Photo may include optional equipment.

 **HYUNDAI**
CONSTRUCTION EQUIPMENT AMERICAS, INC.

PRIDE AT WORK

Hyundai Heavy Industries strives to build state-of-the-art earthmoving equipment to give every operator maximum performance, more precision, versatile machine preferences, and proven quality.

Take pride in your work with Hyundai!



Robex 80CR-9A

Machine Walk-Around

Rugged Upper and Lower Frame

The upper frame is designed with optimum structural integrity to absorb impact and operational stress. The x-style center frame and reinforced box section track frame provide exceptional strength and longer service life to withstand tough working conditions.

Engine Technology

The fuel efficient, Tier 4 Final certified Yanmar 4TNV98 engine provides proven, reliable power. This engine is electronically controlled for optimum fuel to air ratio and clean, efficient combustion and provides low noise, anti-restart features.

Efficient Control System

All control devices are arranged for higher productivity and improved operator comfort. Efficient and ergonomic controls allow an operator to control the machine in any working environment. A safety lever on the left-side console is provided to prevent exiting the cabin while hydraulic controls are live.

Advanced Hydraulic System

The R80CR-9A's advanced hydraulic system includes an arm flow summation system, boom holding system and a swing parking brake for smooth and fine control. Other valuable features include a hydraulic damper in the travel pedal, and a hydraulically lubricated swing reducer with a leak-free grease chamber.

Comfortable and Durable Cabin

The cabin is roomy and ergonomically designed, for reduced noise and good visibility. The cabin frame meets international standard TOPS, ROPS, FOPS ensuring operator safety.

Operator Convenience

Convenient operator features include a suspension seat, excellent visibility, and variable storage space for advanced operator comfort. The newly designed LED cluster provides current information, including engine RPM, engine coolant, fuel level, and electric components. A hydraulic function safety lock and auto diagnostic features are also available. Lock and failure diagnosis functions are also integrated.

A powerful air conditioning system and Radio & USB player contribute to a productive work environment.

Easy and Simple Maintenance

Wide open access of doors, covers, hoods is designed for easier maintenance. The air cleaner and centralized grease fittings are also integrated for easy service.

Extended Life of Components

Long life components and wear parts, including hydraulic filters, oil, shims, and bushings, help to reduce operating costs.



PREFERENCE

Operating a 9A series is unique to every operator. Operators can fully customize their work environment and operating preferences to fit their individual needs.



*Photo may include optional equipment.

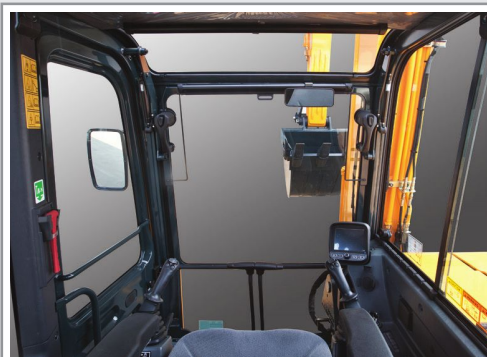

Wide Cabin with Excellent Visibility

The newly designed cabin was conceived for more space, a wider field of view and operator comfort. Special attention was given to a clear, open and convenient interior with plenty of visibility on the machine surroundings and the job at hand. This well balanced combination of precision aspects put the operator in the perfect position to work safely and securely.

Operator Comfort

The R80CR-9A operator's cab is designed for a comfortable operating experience. An ergonomically designed suspension seat, adjustable arm rests and a spacious environment helps to minimize operator fatigue. Control levers are easily accessible and an instrument display is provided to keep the operator informed of pertinent machine information.

1. A large upper roof glass provides additional visibility and a roller shade is provided to reduce glare and sunlight.
2. An advanced audio system with AM/FM stereo with USB player input, plus remotely located control is perfect for listening to music favorites.
3. A hands-free cell phone function is available for safe and convenient phone use.
4. Ergonomically designed joysticks reduce operator fatigue during the work day.
5. Accel dial with LED lamp is easy to control and recognizable in darkness.
6. Multiple storage compartments are available for additional convenience.



Enhanced Cabin

Hyundai's R80CR-9A is equipped for convenience and productivity.

1. Adjustable position window prevents window movement while operating.
2. A sliding fold-in front window is easily opened and safely stored in an open position to improve ventilation and visibility.
3. A tilt-up left side control console provides easier entrance and exit from the cab.
4. A full auto air-conditioning system provides the operator with optimum air temperature.

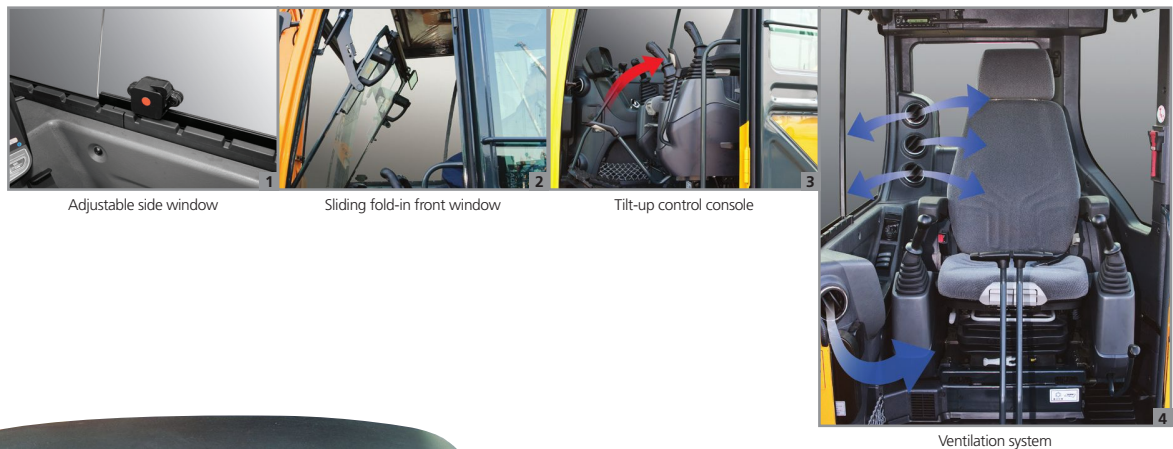

Operator - Friendly Cluster

The advanced new LED cluster allows the operator to select his personal machine preferences. The monitor displays engine rpm, engine oil temperature, water temperature and information for all electronic devices.

Button selections are provided for auto idle mode, max power mode, and travel speed. A security feature is also provided to prevent the machine from starting without a proper password.

PRECISION & PERFORMANCE

Innovative hydraulic system technologies make the 9A series fast, smooth and easy to control.
9A series is designed for maximum performance to keep the operator working productively.



*Photo may include optional equipment.

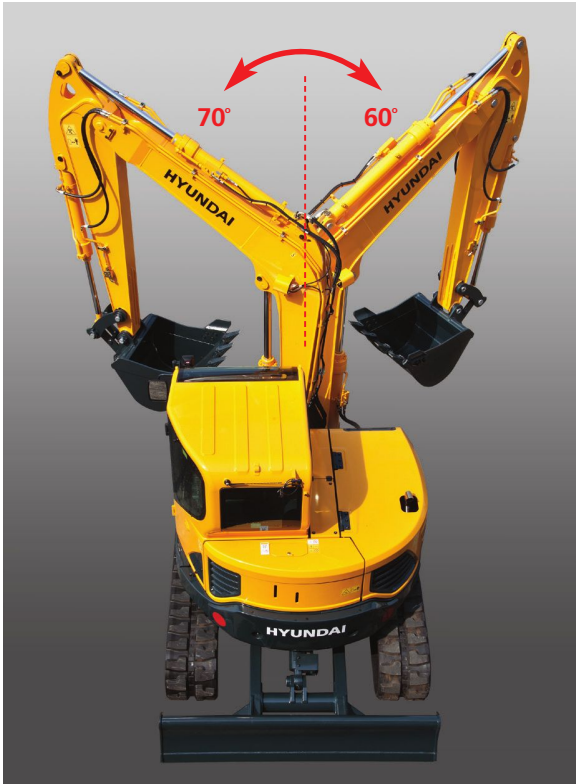

Boom Swing

The R80CR-9A's boom swing function is designed for efficient work in congested residential and urban areas. The boom can be offset left or right within an operating range. Plus, increased swing torque provides enhanced operating capability on the slope.

Improved Hydraulic System

Optimized matching between the joystick and main control valve improves fine control and smoothness of operation. An arm flow summation system provides energy savings, reduced cavitation and increased speed. To improve safety and avoid boom drift the R80CR-9A is equipped with an integrated boom holding system.

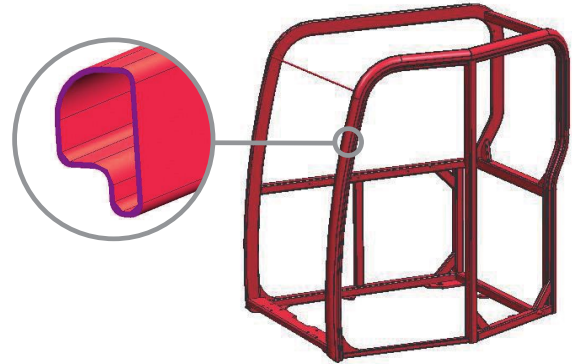
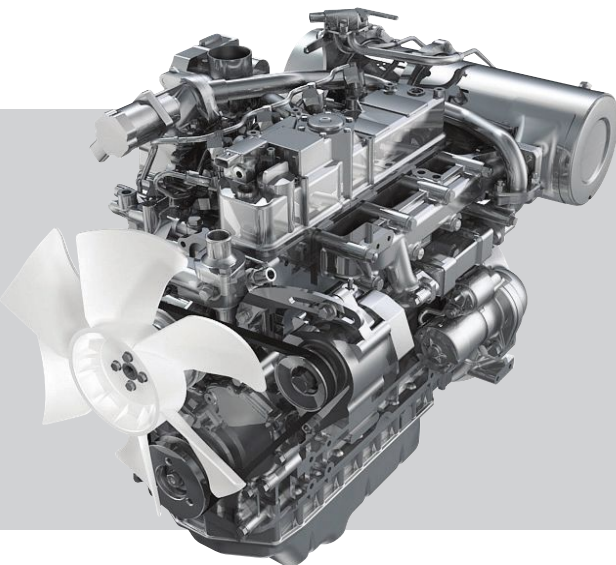

Structure Strength

The R80CR-9A cabin structure has been fitted with stronger but slimmer tubing for added safety and improved visibility. Low-stress, high strength steel is integrally welded to form a stronger, more durable upper and lower frame. Structural integrity was tested by way of FEM (Finite Elements Method) analysis and long-term durability tests.



Short Tail Swing

R80CR-9A's short tail swing radius allows the operator work in confined areas like close to buildings on roadways, and in urban areas. This compact radius design provides easy and efficient operation in any limited space work environment.

Yanmar 4TNV98C

The Highest Engine Power in its Class

Yanmar 4TNV98C engine provides 24.6 kgf.m (178 lbf.ft) of maximum torque with 66.9 HP at 2,400rpm of rated power. This means the R80CR-9A runs with the most power in its class, giving you more power to get the job done.

PROFITABILITY

9A series is designed to maximize profitability through improved efficiencies, enhanced service features and longer life components.



*Photo may include optional equipment.

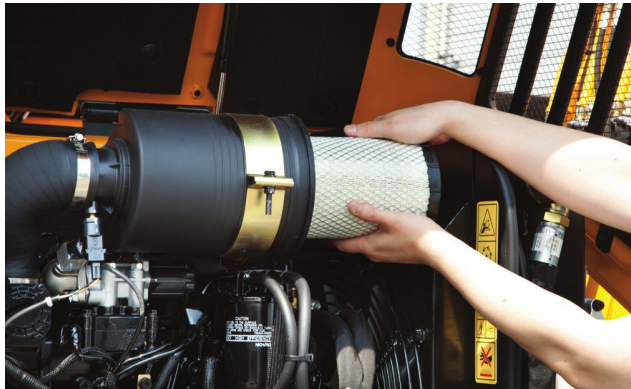

Easy Change Air Cleaner

The R80CR-9A is equipped with a durable plastic air cleaner designed for easy maintenance.



Wide Open Engine hood

A newly designed full-open type engine hood makes service more convenient on the R80CR-9A.

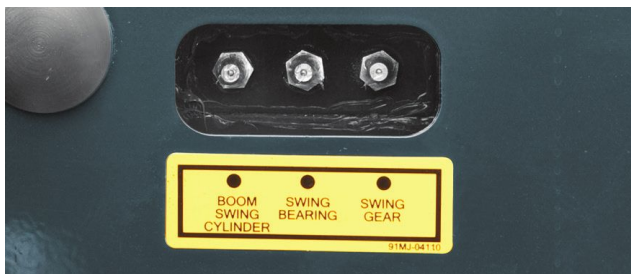

Centralized Grease Fittings

A centralized lubrication bank is available for faster, easier service and maintenance.



Improved Durability

The R80CR-9A's reinforced arm lug & dozer cylinder cover provide better reliability on the tough working condition.



Tilting Cabin

R80CR-9A's tiltable cabin provides the operator with convenient maintenance.

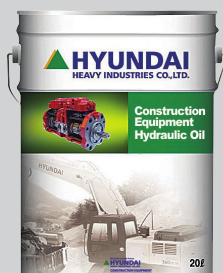

Long-Life Components

9A series excavators were designed with bushings designed for long-life lube intervals (250 hrs) & polymer shims (wear resistant, noise reducing), long-life hydraulic filters (1,000hrs), long-life hydraulic oil (5,000hrs), more efficient cooling systems and integrated preheating systems which extend service intervals, minimize operating costs and reduce machine down time.

Specifications

ENGINE

MODEL		YANMAR 4TNV98C	
Type		Water cooled, 4 cycle diesel 4 cylinders in line, direct injection, low emission	
Rated flywheel horsepower	SAE	J1995 (gross)	66.9 HP (49.9 kW) at 2,400 rpm
		J1349 (net)	65.1 HP (48.5 kW) at 2,400 rpm
	DIN	6271/1 (gross)	67.8 PS (49.9 kW) at 2,400 rpm
		6271/1 (net)	66 PS (48.5 kW) at 2,400 rpm
Max. torque		24.6 kgf·m (178 lbf·ft) at 1,560 rpm	
Bore X stroke		98 mm (3.86") x 110 mm (4.33")	
Piston displacement		3,319 cc (202 cu in)	
Batteries		2 x 12 V x 100 AH	
Starting motor		12V-3.0 kW	
Alternator		12V-80 Amp	

HYDRAULIC SYSTEM

MAIN PUMP	
Type	Variable displacement piston pumps
Max. flow	2 X 72 ℓ/min (19 US gpm / 15.8 UK gpm) pumps
Sub-pump for pilot circuit	Gear pump

Cross-sensing and fuel saving pump system

HYDRAULIC MOTORS

Travel	Two speed axial piston motor with counter balance valve and parking brake
Swing	Axial piston motor with automatic brake

RELIEF VALVE SETTING

Implement circuits	P1 / P2 : 280 kgf/cm ² (3,980 psi) P3 : 230 kgf/cm ² (3,270 psi)
Travel circuit	280 kgf/cm ² (3,983 psi)
Swing circuit	230 kgf/cm ² (3,271 psi)
Pilot circuit	35 kgf/cm ² (500 psi)
Service valve	Installed

HYDRAULIC CYLINDERS

No. of cylinder bore X stroke	Boom: 1-115 x 850 mm (4.5" x 33.5")
	Arm: 1-100 x 870 mm (3.9" x 34.3")
	Bucket: 1-85 x 685 mm (3.3" x 27.0")
	Boom swing: 1-110 x 744 mm (4.3" x 29.3")
	Dozer blade: 1-130 x 152 mm (5.1" x 6.0")

NOISE LEVEL (CAB)

Noise levels (dynamic valve)	
LwA	99 dB
LpA	76 dB

TRAVEL SYSTEM

Drive method	Full hydrostatic type	
Drive motor	Axial piston motor, in-shoe design	
Reduction system	Planetary reduction gear	
Max. drawbar pull	7,400 kgf (16,310 lbf)	
Max. travel speed (high) / (low)	Steel track & Road Liner	4.6 km/hr (2.9 mph) / 2.8 km/hr (1.7 mph)
	Rubber track	5.1 km/hr (3.2 mph) / 3.1 km/hr (1.9 mph)
Gradeability	35° (70%)	
Parking brake	Multi-wet disc	

CONTROLS

Pilot pressure operated joysticks and pedals with detachable lever provide almost effortless and fatigueless operation.

Pilot control	Two joysticks with one safety lever (LH): Arm swing, Boom swing (RH): Boom and bucket (ISO)
Traveling and steering	Two levers with pedals
Engine throttle	Electric, Dial type

SWING SYSTEM

Swing motor	Axial piston motor
Swing reduction	Planetary gear reduction
Swing bearing lubrication	Grease-bathed
Swing brake	Multi wet disc
Swing speed	8.1 rpm

COOLANT & LUBRICANT CAPACITY

(Refilling)	liter	US gal	UK gal
Fuel tank	120.0	31.7	26.4
Engine coolant	11.0	2.9	2.4
Engine oil	11.6	3.1	2.6
Final drive(each)	1.2	0.3	0.3
Hydraulic tank	71.0	18.8	15.6
Hydraulic system	120.0	31.7	26.4

UNDERCARRIAGE

X-leg type center frame is integrally welded with reinforced box-section track frames. The undercarriage includes lubricate rollers, track adjusters with shock absorbing springs and sprockets, and track chain with triple grouser shoes.

Center frame	X - leg type
Track frame	Pentagonal box type
No. of track shoe on each side	39
No. of upper roller on each side	1
No. of lower roller on each side	5

OPERATING WEIGHT (APPROXIMATE)

Operating weight, including 3,400 mm (12' 2") boom, 1,670 mm (5' 6") arm, SAE heaped 0.28 m³ (0.37 yd³) digging bucket, lubricant, coolant, full fuel tank, hydraulic tank and the standard equipment.

MAJOR COMPONENT WEIGHT

Upperstructure	4,090 kg (9,020 lb)
Mono boom(with arm cylinder)	550 kg (1,210 lb)

OPERATING WEIGHT

Operating weight	Steel (450)	8,350 kg (18,410 lb)
	Steel (600)	8,510 kg (18,760 lb)
	Rubber (450)	8,250 kg (18,190 lb)

·Mono boom with blade

Ground Pressure	Steel (450)	0.39 kgf.m / cm ² (5.53 psi)
	Steel (1,600)	0.30 kgf.m / cm ² (4.23 psi)
	Rubber (450)	0.38 kgf.m / cm ² (5.44 psi)

BUCKETS

Capacity		Width		Weight
SAE heaped	CECE heaped	Without side cutters	With side cutters	
0.14 m ³ (0.18 yd ³)	0.13 m ³ (0.17 yd ³)	390 mm (15.4")	470 mm (18.5")	185 kg (410 lb)
0.28 m ³ (0.37 yd ³)	0.25 m ³ (0.33 yd ³)	730 mm (28.7")	810 mm (31.9")	230 kg (510 lb)

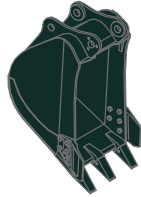

SAE heaped

0.14 m³ (0.18 yd³)

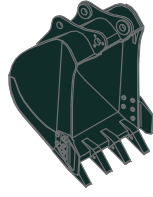

0.28 m³ (0.37 yd³)

DIGGING FORCE (ISO)

	1.67m Arm	2.2m Arm
Bucket	5,700 kgf	5,700 kgf
	55.9 kN	55.9 kN
	12,570 lbf	12,570 lbf
Arm	4,300 kgf	3,540 kgf
	42.2 kN	34.7 kN
	9,480 lbf	7,800 lbf

Lifting Capacity

R80CR-9A

Rating over-front Rating over-side or 360 degree

Boom : 3.4m (12' 2") / Arm : 1.67 m (5' 6") / Bucket : 0.28m³ (0.37yd³) SAE heaped / Dozer blade down

Load point height m (ft)	Load radius						At max. reach		Reach m (ft)
	1.5 m (5 ft)		3.0 m (10 ft)		4.5 m (15 ft)		Capacity		
4.5 m (15 ft)	kg				*1550	1480	*1470	1040	5.74
	lb				*3420	3260	*3240	2290	(17.9)
3.0 m (10 ft)	kg				*1740	1430	*1530	780	6.23
	lb				*3840	3150	*3370	1720	(20.4)
1.5 m (5 ft)	kg		*4050	2510	*2260	1320	*1620	700	6.45
	lb		*8930	5530	*4980	2910	*3570	1540	(21.2)
Ground	kg		*4830	2320	*2650	1230	*1710	740	6.20
Line	lb		*10650	5110	*5840	2710	*3770	1630	(20.3)
-1.5 m (-5 ft)	kg	*4730	*4730	*4410	*2550	1210	*1760	940	5.38
	lb	*10430	*10430	*9720	*5620	2670	*3880	2070	(17.7)
-3.0 m (-10 ft)	kg		*2810	2430					
	lb		*6190	5360					









- Lifting capacity is based on SAE J1097, ISO 10567.
- Lifting capacity of the Robex Series does not exceed 75% of the tipping load with the machine on firm, level ground or 87% of full hydraulic capacity.
- The load point is a hook located on the back of the bucket.
- (*) indicates the load limited by hydraulic capacity.

Lifting Capacity











R80CR-9A

 Rating over-front  Rating over-side or 360 degree











Boom : 3.4m (12' 2") / Arm : 1.67 m (5' 6") / Bucket : 0.28m³ (0.37yd³) SAE heaped / Dozer blade up

Load point height m (ft)	Load radius						At max. reach		Reach m (ft)	
	1.5 m (5 ft)		3.0 m (10 ft)		4.5 m (15 ft)		Capacity			
										
4.5 m (15 ft)	kg					*1550	1380	1110	970	5.74
	lb					*3420	3040	2450	2140	(17.9)
3.0 m (10 ft)	kg					1540	1340	840	730	6.23
	lb					3400	2950	1850	1610	(20.4)
1.5 m (5 ft)	kg		2770	2320	1430	1230		760	650	6.45
	lb		6110	5110	3150	2710		1680	1430	(21.2)
Ground Line	kg		2570	2140	1330	1140		790	680	6.20
	lb		5670	4720	2930	2510		1740	1500	(20.3)
-1.5 m (-5 ft)	kg	*4730	*4730	2570	2140	1310	1120	1010	870	5.38
	lb	*10430	*10430	5670	4720	2890	2470	2230	1920	(17.7)
-3.0 m (-10 ft)	kg		2690	2250						
	lb		5930	4960						

Boom : 3.4m (12' 2") / Arm : 2.20 m (7' 3") / Bucket : 0.28m³ (0.37yd³) SAE heaped / Dozer blade

Load point height m (ft)	Load radius								At max. reach		Reach m (ft)	
	1.5 m (5 ft)		3.0 m (10 ft)		4.5 m (15 ft)		6.0 m (20 ft)		Capacity			
												
4.5 m (15 ft)	kg					*1180	*1180			*1280	810	6.17
	lb					*2600	*2600			*2820	1790	(20.2)
3.0 m (10 ft)	kg					*1410	*1410	*1400	820	*1320	630	6.84
	lb					*3110	*3110	*3090	1810	*2910	1390	(22.4)
1.5 m (5 ft)	kg		*3280	2580	*1970	1310	*1570	780	*1390	*1390	570	7.03
	lb		*7230	5690	*4340	2890	*3460	1720	*3060	*3060	1260	(23.1)
Ground Line	kg	*1900	*1900	*4600	2270	*2470	1190	*1730	730	*1460	590	6.80
	lb	*4190	*4190	*10140	5000	*5450	2620	*3810	1610	*3220	1300	(22.3)
-1.5 m (-5 ft)	kg	*3590	*3590	*4590	2220	*2580	1140			*1500	720	6.09
	lb	*7910	*7910	*10120	4890	*5690	2510			*3310	1590	(20.0)
-3.0 m (-10 ft)	kg	*5800	*5800	*3530	2290	*1890	1190			*1360	1220	4.58
	lb	*12790	*12790	*7780	5050	*4170	2620			*3000	2690	(15.0)

Boom : 3.4m (12' 2") / Arm : 2.20 m (7' 3") / Bucket : 0.28m³ (0.37yd³) SAE heaped / Dozer blade up

Load point height m (ft)	Load radius								At max. reach		Reach m (ft)	
	1.5 m (5 ft)		3.0 m (10 ft)		4.5 m (15 ft)		6.0 m (20 ft)		Capacity			
												
4.5 m (15 ft)	kg					*1180	*1180			870	750	6.17
	lb					*2600	*2600			1920	1650	(20.2)
3.0 m (10 ft)	kg					*1410	1350	880	760	680	580	6.84
	lb					*3110	2980	1940	1680	1500	1280	(22.4)
1.5 m (5 ft)	kg		2850	2390	1420	1220	840	720	610	610	520	7.03
	lb		6280	5270	3130	2690	1850	1590	1340	1340	1150	(23.1)
Ground Line	kg	*1900	*1900	2520	2090	1290	1100	790	670	640	540	6.80
	lb	*4190	*4190	5560	4610	2840	2430	1740	1480	1410	1190	(22.3)
-1.5 m (-5 ft)	kg	*3590	*3590	2460	2040	1240	1050			780	660	6.09
	lb	*7910	*7910	5420	4500	2730	2310			1720	1460	(20.0)
-3.0 m (-10 ft)	kg	*5800	*5800	2540	2110	1290	1100			1320	1130	4.58
	lb	*12790	*12790	5600	4650	2840	2430			2910	2490	(15.0)

- Lifting capacity is based on SAE J1097, ISO 10567.
- Lifting capacity of the Robex Series does not exceed 75% of the tipping load with the machine on firm, level ground or 87% of full hydraulic capacity.
- The load point is a hook located on the back of the bucket.
- (*) indicates the load limited by hydraulic capacity.

Dimensions & Working Range

R80CR-9A DIMENSIONS

unit: mm(ft · in)

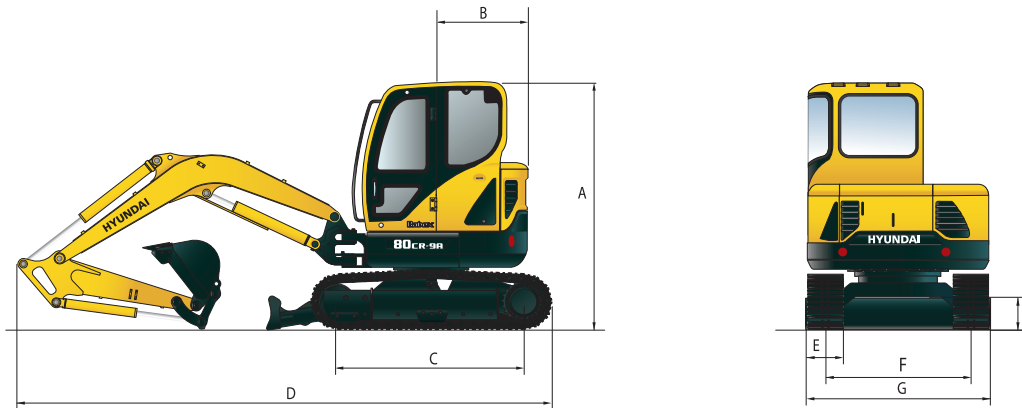

		mm (ft·in)	
A	Overall height of cab	2,750 (9')	
B	Tail swing radius	1,280 (4' 2")	
C	Tumbler distance	2,200 (7' 3")	
D	Overall length	6,400 (20' 9")	
E	Track shoe width	Steel	450 (1' 6")
		Rubber	450 (1' 6")
F	Track gauge		1,850 (6' 1")
G	Overall width		2,300 (7' 7")
H	Ground clearance		360 (1' 2")

R80CR-9A WORKING RANGE

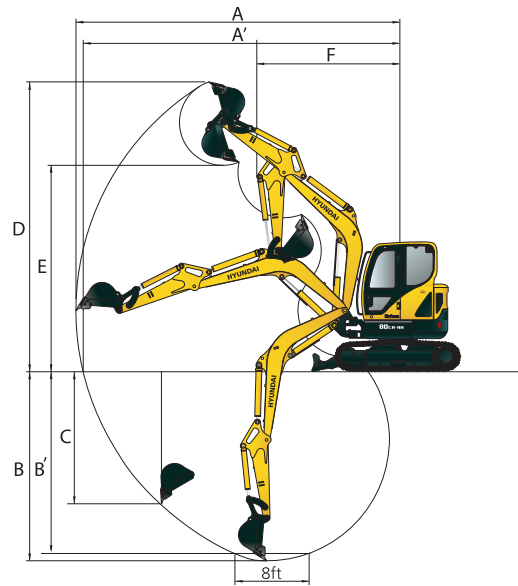

unit: mm(ft · in)

Boom length	3,400 (11' 2")	
Arm length	1,670 (5' 6")	2,200 (7' 3")
A Max. digging reach	6,960 (22' 10")	7,390 (24' 3")
A' Max. digging reach on ground	6,820 (22' 5")	7,250 (23' 9")
B Max. digging depth	4,180 (13' 7")	4,620 (15' 2")
B' Max. digging depth (8 ft)	3,780 (12' 5")	4,330 (14' 2")
C Max. vertical wall digging depth	3,570 (11' 9")	4,040 (13' 3")
D Max. digging height	6,750 (22' 1")	7,040 (23' 1")
E Max. dumping height	4,730 (15' 6")	5,050 (16' 7")
F Min. swing radius	2,500 (8' 2")	2,610 (8' 7")

Notes

Notes

STANDARD EQUIPMENT

ISO standard cabin

- Cabin ROPS(ISO 12117-2)
FOPS(ISO 3449)
FOG(ISO 10262 Level I)
- All-weather steel cab with all-around visibility
- Safety glass windows
- Rise-up type windshield wiper
- Sliding fold-in front window
- Sliding side window
- Lockable door
- Accessory box & Ash-tray

Centralized monitoring

- Engine speed
- Gauges
Fuel level gauge

- Engine coolant temperature gauge
- Warning
Fuel level
Engine oil pressure
Engine coolant temperature
Hyd. oil temperature
Low battery
Air cleaner clogging
- Fuel prefilter
- Air-conditioner & heater
- Single acting piping kit (breaker, etc)
- Door and cab locks, one key
- Radio / USB player with remote control
- Outside rear view mirror
- Fully adjustable suspension seat with seat belt

- Console box tilting system(LH.)
- Three front working lights
- Electric horn
- Battery (1 x 12 V x 100 AH)
- Battery master switch
- 12 volt power supply
- Automatic swing brake
- Removable reservoir tank
- Water separator, fuel line
- Mono boom (3.4 m, 11' 2")
- Arm (1.67 m, 5' 6")
- Track shoes (450 mm, 1' 6")
- Track rail guard
- Starting aid (air grid heater) cold weather

OPTIONAL EQUIPMENT

Fuel filler pump (35l/min, 9.2 US gpm)

Beacon lamp

Double acting piping kit (clamshell, etc)
with proportional RCV Lever

Single acting piping kit (Breaker)

Safety Lock V/V for Arm cylinder

Track pad (450mm, 1' 6")

Accumulator, work equipment lowering

Electric transducer

Travel alarm

Quick coupler

Rubber track (450mm, 1' 6")

Rubber PAD (450mm, 1' 6")

Track shoes (600mm, 1' 12")

Long arm (2.2m, 7' 3")

Tool kit

Cabin rear work lamp

Lever pattern change valve (2pattern)

Additional CWT (400kg, 880lb)

* Standard and optional equipment may vary. Contact your Hyundai dealer for more information. The machine may vary according to International standards.

* The photos may include attachments and optional equipment that are not available in your area.

* Materials and specifications are subject to change without advance notice.

* All imperial measurements rounded off to the nearest pound or inch.

PLEASE CONTACT



6100 Atlantic Blvd Norcross, GA 30071
TEL (678) 823 7777 FAX (678) 823 7778