



TD-14M

CRAWLER DOZER
STD-LT-LGP



EXTRA

■ **Net Horsepower**
120 kW (160 hp)

■ **Blade Capacity**
up to 4.28 m³ (5.6 yd³)

■ **Operating Weight**
15550 kg (34,282 lb) STD
16550 kg (36,486 lb) LT
17650 kg (38,911 lb) LGP

Engine

The Cummins QSB6.7 engine meets U.S. EPA Tier 3 and EU Stage IIIA emission standards. This highly successful, common rail engine has charge air cooling and is turbocharged for fuel economy and strong performance. This engine combines the highly efficient electronically controlled fuel injection system with high reliability, durability and long maintenance intervals. The engine is equipped with air grid heater for starting in cold weather.

Power Train

The modular drive train includes the Cummins engine, single stage torque converter, full power-shift transmission, geared 2-speed steering and the final drives.

Pre-set travel speed selection and automatic downshift system provides the operator with comfortable operation and high productivity without the need for manual downshifting in many operations.

The high capacity brakes are operated by a centrally located foot pedal.

Undercarriage arrangements

Three distinct models of the dozer are available for specific job-site applications:

TD-14M Extra sets new pe

Working Equipment

The machine equipped with a blade and a ripper is ideal for all construction projects performing such tasks as clearing and grading, sloping road banks, backfilling and final grade work.



- Standard (STD)
- Long Track (LT) arrangement which gives the dozer good balance, makes grading on slopes easy
- Low Ground Pressure (LGP) arrangement specially designed to work in soft and muddy job sites

performance standards





Durable construction

Semi-U blade of 4.28 m³ (5.6 yd³) (STD)



6-way hydraulic angle blade of 3.2 m³ (4.2 yd³) (STD & LT) and 3.8 m³ (5.0 yd³) (LGP)



Straight blade of 3.05 m³ (4.0 yd³) (LGP)



A variety of blades suitable for various operating conditions and job requirements are available. STD and LT versions can be equipped with Semi-U or 6-Way blades and the LGP version mounts either a Straight or 6-Way blade with the full width 915 mm (36") track shoe.

The modern and comfortable six sided cab provides the operator superior all-around visibility and excellent view of both the blade and the ripper equipment.

The sound suppressed cab with:

- air recirculation system
 - pressurized air conditioner/heater
 - adjustable air suspension seat with arm rests
 - AM/FM radio, CD with MP3/USB compatibility
 - in-cab and outside mounted mirrors
 - interior light and retractable sun visor
- is protected by ROPS/FOPS to meet SAE J1040, J231 standards.

The instrument panel provides the operator with the information about the condition of the machine during operation.

The left hand joystick controls transmission and steering drive for up and down shifting, steering Hi/Lo selection and LH/RH gradual turns.

The right hand ergonomical levers control blade and ripper movements. Pilot operated hydraulic controls are offered as an option.



yd³)



ped
noes.



The optional three-shank, parallelogram type ripper is ideal for ripping in tough material.



Electrical system master switch located on LH side is accesible from ground level.

Specification

ENGINE

* Make and Model	Cummins QSB6.7
Type	In-line, 6-cylinder
Aspiration	Turbocharged and CAC
Fuel system	HPCR Electronic
Gross Horsepower, SAE J1995	129 kW (173 hp)
Net Horsepower, SAE J1349/ISO 9249	120 kW (160 hp)
Rated rpm	1800 rpm
Max. torque @ 1350 rpm	893 Nm (659 ft-lb)
Displacement	6.7 l (408 in ³)
Bore and stroke	107 x 124 mm (4.21" x 4.88")
Air cleaner	dry type, dual stage with dust discharge valve

*Meets EU Stage IIIA and EPA Tier 3 emission regulations

TRANSMISSION & TORQUE CONVERTER

Modular, countershaft type power shift, electro-hydraulic control. Preset travel speed selection and auto-downshift. Single stage 370 mm (14.6") torque converter with a 2.1:1 stall ratio drives to transmission through a double universal joint.

TRAVEL SPEEDS

Gear	Range	Forward		Reverse	
		km/h	(mph)	km/h	(mph)
1 st	Low	2.9	(1.8)	3.6	(2.2)
	High	4.0	(2.5)	4.8	(3.0)
2 nd	Low	5.0	(3.1)	6.0	(3.7)
	High	6.6	(4.1)	8.0	(5.0)
3 rd	Low	8.2	(5.1)	9.8	(6.1)
	High	10.8	(6.7)	12.9	(8.0)

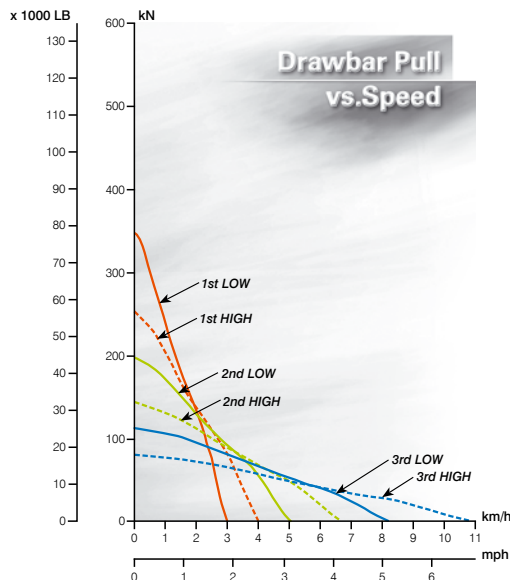

STEERING & BRAKING

Two speed geared steering module provides gradual turns while maintaining full power to both tracks plus conventional clutch-brake performance for tight or pivot turns. This type of steering system offers superior traction in all types of operations and terrain.

Coupled to 3-speed transmission, the 2-speed steering provides 6 speeds forward and 6 reverse. The left hand joystick controls transmission and steering drive for up and down shifting, steering, Hi/Lo selection and LH/RH gradual geared turn.

Foot pedal applies both brakes for parking and downhill control. Brakes are spring applied and hydraulically released.

FINAL DRIVES

Double-reduction module provides desired gear reduction at the sprocket. Ring-type sprocket distributes wear evenly over track bushings, letting every tooth ride free one-half of the time to reduce wear. Final drives or sprockets are replaceable without removing track frames.

TRACK FRAME

All-welded heavy box section track frame is kept in alignment with track frame guides providing true vertical oscillation.

Track rollers, each side STD (LT, LGP)	7(8)
Top idlers, each side	2
Front idlers (drum type)	1
All rollers and idlers	lifespan lubricated

TRACKS

Lubricated Track System (LTS) virtually eliminates internal pin and bushing wear through use of a patented seal assembly. The split master link reduces chain removal and installation time.

	STD	LT	LGP
Track shoe width, standard	560 mm (22")	560 mm (22")	915 mm (36")
Track shoes, each side	40	46	46
Ground contact area	2.9 m ² (4,495 in ²)	3.6 m ² (5,580 in ²)	5.8 m ² (8,990 in ²)
Ground pressure (w/std. equipment)	55.5 kPa (8.0 psi)	47.5 kPa (6.9 psi)	31.4 kPa (4.6 psi)
Height of grouser	65 mm (2.56")		
Ground clearance	430 mm (16.9")		

REFILL CAPACITIES

	Liter	(US gal)
Fuel tank	380	(100)
Cooling system	34	(9)
Crankcase w/filter	18.5	(4.9)
Transmission system	125	(33)
Final drive, each (STD, LT)	28	(7.4)
Final drive, each (LGP)	46	(12)
Hydraulic reservoir	59	(15.6)

OPERATING WEIGHT

Includes standard equipment, 6-way blade and full fuel tank:

	STD	LT	LGP
Canopy ROPS/FOPS	15 550 kg (34,282 lb)	16 550 kg (36,486 lb)	17 650 kg (38,911 lb)
Cab ROPS	16 100 kg (35,494 lb)	17 100 kg (37,699 lb)	18 200 kg (40,124 lb)

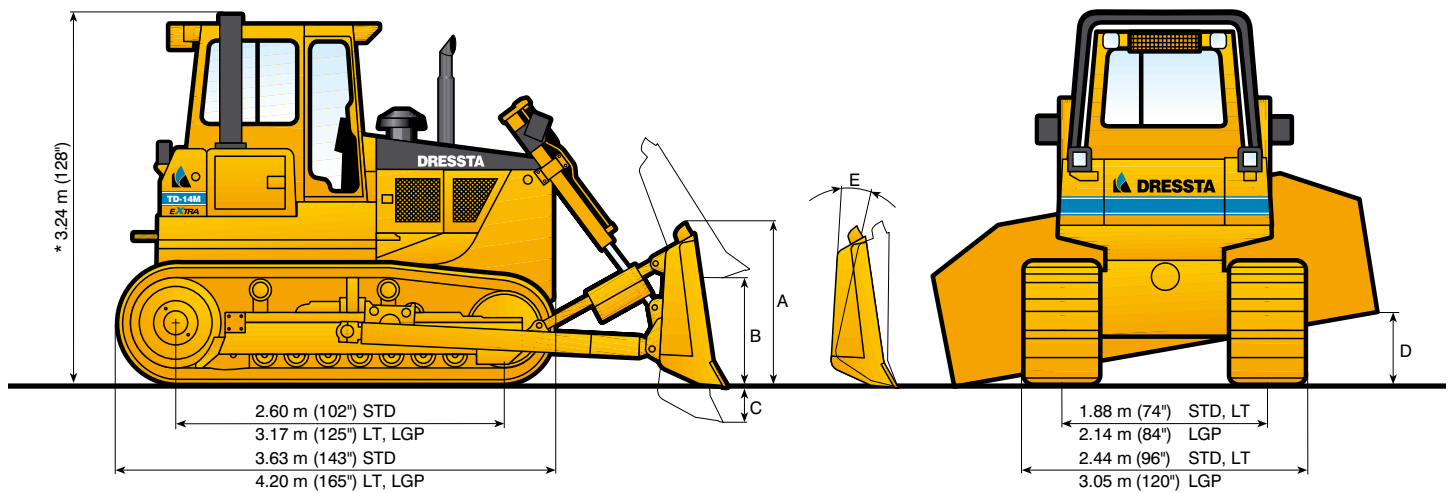

* DIMENSION INCLUDES 65 mm (2.56") GROUSER HEIGHT

OVERALL DIMENSIONS WITH EQUIPMENT

	UNDERCARRIAGE	BLADE SELECTION			
		SEMI-U	6-WAY	STRAIGHT	6-WAY
Length with blade and drawbar	STD	5.13 m (16'10")	5.32 m (17'5")		
	LT	5.69 m (18'8")	5.54 m (18'2")		
	LGP	—	—	5.50 m (18')	5.54 m (18'2")
Length with blade and ripper	STD	6.30 m (20'8")	6.49 m (21'4")	—	—
	LT	6.87 m (22'16")	6.72 m (22'1")	—	—
Width, blade angled	STD & LT	—	2.92 m (9'7")	—	—
	LGP	—	—	—	3.48 m (11'5")
Width over trunnions	STD & LT	2.71 m (8'11")	—	—	—
	LGP	—	—	3.30 m (10'10")	—

BLADE SPECIFICATIONS

UNDERCARRIAGE	BLADE SELECTION	STD<		LGP	
		SEMI-U	6-WAY	STRAIGHT	6-WAY
Track shoes		22"/24"	22"/24"	36"	36"
Blade capacity, SAE J1265		4.28 m ³ (5.6 yd ³)	3.20 m ³ (4.2 yd ³)	3.05 m ³ (4.0 yd ³)	3.80 m ³ (5.0 yd ³)
Blade dimensions: – width over end bits – height		3.37 m (133")	3.22 m (127")	3.70 m (146")	3.83 m (151")
	A	1.23 m (48")	1.20 m (47")	1.02 m (40")	1.17 m (46")
Max. lift, straight	B	STD 990 mm (39") LT 1060 mm (42")	STD 1090 mm (42.9") LT 1086 mm (42.7")	1056 mm (41.6")	1085 mm (42.7")
	C	STD 515 mm (20.3") LT 500 mm (19.7")	STD 580 mm (22.8") LT 536 mm (21.1")	500 mm (19.7")	536 mm (21.1")
Max. tilt adjustment	D	STD 545 mm (21") LT 510 mm (20")	510 mm (20")	595 mm (23")	595 mm (23")
		—	25°	—	25°
Max. pitch adjustment	E	9°	7°	9°	8°
Weight of blade equipment		2045 kg (4,508 lb)	2066 kg (4,555 lb)	1955 kg (4,310 lb)	2202 kg (4,855 lb)

RIPPER SPECIFICATION

TYPE	MULTI-SHANK
Tool Beam	
Overall width	2040 mm (80.3")
Cross section (height x width)	229 x 254 mm (9" x 10")
Ground clearance under tool beam: – ripper raised – ripper lowered	1160 mm (46")
	60 mm (2.4")
Shanks	
Number of shanks per ripper, max.	3
Spacing center to center	940 mm (37")
Penetration, max.	660 mm (26")
Ground clearance, max. raised	568 mm (22")
Shank positions (vertical)	2
Weight	
Complete, including one shank	1422 kg (3,135 lb)
Each additional shank	111 kg (245 lb)
Penetration Force	67 kN (15,062 lb)
Pryout Force	191 kN (42,937 lb)

TD-14M

CRAWLER DOZER

STD-LT-LGP



HYDRAULIC CONTROL SYSTEM

Pump, tandem gear, driven from torque converter.		Cylinders, bore and stroke:	
Output @ rated engine rpm	135 l/min (35.7 gpm)	lift (STD)	90 x 1100 mm (3.5" x 43.3")
Relief valve setting	17.5 MPa (2,540 psi)	lift (LT, LGP)	90 x 930 mm (3.5" x 36.6")
		lift (6-way)	90 x 1000 mm (3.5" x 39.4")
		tilt	140 x 147 mm . (5.5" x 5.8")

STANDARD EQUIPMENT

<ul style="list-style-type: none"> • Air cleaner, dry type, dual stage with dust discharge valve • Alarm, back-up • Alternator, 50 A • Antifreeze, -37°C (-34°F) • Batteries, (2) 12 V, 815 CCA, maintenance free • Brakes, foot, spring applied, hydraulically released • Canopy, 2 post ROPS/FOPS (SAE J1040, J231) • Cooling module; includes radiator, transmission oil cooler, charge air cooler; isolation mounted • Decelerator – right foot pedal and brake – center foot pedal • Diagnostic centers for power train and equipment hydraulic pressures • Ecological drains for engine oil, radiator coolant and hydraulic oil • Engine hood, solid, sloped • Engine side doors, hinged, perforated type • Exhaust pipe extension with elbow • Fan, blower • Filter, engine oil, full flow, "spin-on" type • Filters, power train, equipment hydraulics, fuel, "spin-on" micro glass type • Final drive seal guard • Guards: crankcase, hinged, with front pull hook, transmission, fan, radiator and sprocket rock and dirt deflector • Hitch, retrieval • Horn, electric 	<ul style="list-style-type: none"> • Hydraulic controls, pilot operated, 3-spool valve, 3 rd section plugged, 1-lever (lift/tilt) • Instruments: <ul style="list-style-type: none"> – Engine ECM failure warning lights and switches – Gear, range, drive train and engine diagnostic display – Gauges: fuel level, engine coolant temperature, engine oil pressure, drive train system oil temperature, voltmeter, hourmeter, tachometer – Warning lights: air cleaner filter, drive train oil filters, hydraulic oil filters, transmission/clutch oil low pressure, coolant high temperature, drive train oil high temperature, fan drive oil filter, engine inlet air heater – Audible & visual warning system: low engine coolant level, low engine oil pressure • Lights with guards, 2F – lift cylinders, 2R – fuel tank mounted • Muffler, under engine hood, insulated • Radiator guard door, hinged, louvered • Rear access steps • Receptacle, starting/charging • Seat belt (SAE J386) – 3" wide, retractable • Seat, deluxe, air suspension type, vinyl cover, adjustable with arm rests, swivel 14° to right • Starting aid – air grid heater • Starting, 24 V • Steering, planetary type, 2-speed, left hand single lever control (joystick) 	<ul style="list-style-type: none"> • Strainers, fuel and hydraulic tanks • Tools compartment • Torque converter, single stage • Transmission power shift, 3 speeds forward, 3 reverse, preset travel speed selection and auto-downshift • Water separator, fuel system • UNDERCARRIAGE <ul style="list-style-type: none"> Track frames, oscillating type, lifespan lubricated rollers and idlers Track adjusters, hydraulic Track chain center guides Track chain end guides, integral – STANDARD (STD) <ul style="list-style-type: none"> Track chain, sealed and lubricated (LTS) with split master link, 40 links Track frame, 7 roller, 1880 mm (74") gauge Track shoes, 560 mm (22") square corner – LONG TRACK (LT) <ul style="list-style-type: none"> Track chain, sealed and lubricated (LTS) with split master link, 46 links Track frame, 8 roller, 1880 mm (74") gauge Track shoes, 560 mm (22") square corner – LOW GROUND PRESSURE (LGP) <ul style="list-style-type: none"> Track chain, sealed and lubricated (LTS) with split master link, 46 links Track frame, 8 roller, 2136 mm (84") gauge Track shoes, 915 mm (36") clipped corner
--	--	--

OPTIONAL ATTACHMENTS

<ul style="list-style-type: none"> • AM/FM CD radio • Batteries, cold start (2) 12 V, 960 CCA • Blade Equipment (STD & LT): <ul style="list-style-type: none"> – Semi-U Dozer, 4.28 cu. m (5.6 cu. yd); hydraulic tilt – Angle Dozer (6-way), 3.20 cu. m (4.2 cu. yd) full hydraulic, inside arm with hydraulic tilt, angle and manual pitch • Blade Equipment (LGP): <ul style="list-style-type: none"> – Straight Dozer, 3.05 cu. m (4.0 cu. yd); hydraulic tilt – Angle Dozer (6-way), 3.8 cu. m (5.0 cu. yd) full hydraulic, inside arm with hydraulic tilt, angle and manual pitch • Cab and ROPS Equipment: <ul style="list-style-type: none"> – Air conditioner/heater/pressurizer/defroster, underseat mounted; A/C condenser behind roof – Cab w/sound suppression, 4 wipers w/washers, inside mirror, dome light, tinted safety glass and air recirculation system – Heater /pressurizer/ defroster – ROPS for cab or forestry attachment 	<ul style="list-style-type: none"> – Sun visor in cab – Sweeps, forestry, front and rear – Screen rear (includes deduct for standard rear access steps) – Seat, air suspension, fabric cover (for use w/cab) • Drawbar, fixed • Engine enclosures: perforated hood and perforated side doors • Exhaust pipe extension w/guard, for sweeps • Guards: <ul style="list-style-type: none"> – Crankcase, severe service w/front pull hook – Tank guard, bolted (includes deduct for standard rear access steps) – Track roller, full length (STD) – Track roller, full length (LT-LGP) – Transmission, severe service • Hydraulic controls, pilot operated: <ul style="list-style-type: none"> – 3-spool valve, (3 rd section plugged), 1-lever (for use with 6-way) – 3-spool valve, 2-lever (for use with ripper and tilt or 6-way) 	<ul style="list-style-type: none"> • Inspection lamp, 24 V, portable with 6 m (20') cable • Instrument panel guard (for use w/Canopy ROPS/FOPS) • Lights for Canopy ROPS/FOPS, 2F – 2R • Lights for cab, 2F – 2R • Lights for cab and sweeps, 2F – 2R • Lights, ROPS mounted (not for use with sweeps) for use with cab, 2F • Mirrors, 2 pcs. exterior • Ripper, multi-shank, max. 3 shanks • Screening package; cab for screens installation must be ordered: <ul style="list-style-type: none"> – Screens for cab windows (front, rear, side and doors) – Screens for tractor and cab lights • Starting/charging receptacle plug assembly • Tools in metal box • Track shoes (STD-LT), 610 mm (24") square corner. Access steps on track frame, bolt-on. • Vandalism protection
---	--	---

Specifications subject to change without notice. Illustrations and pictures may include optional attachments and accessories and may not include all standard equipment.

DRESSTA

www.dressta.com.pl
sales@dressta.com.pl